

VIGO ORION BATHTUB DOOR

VG06071

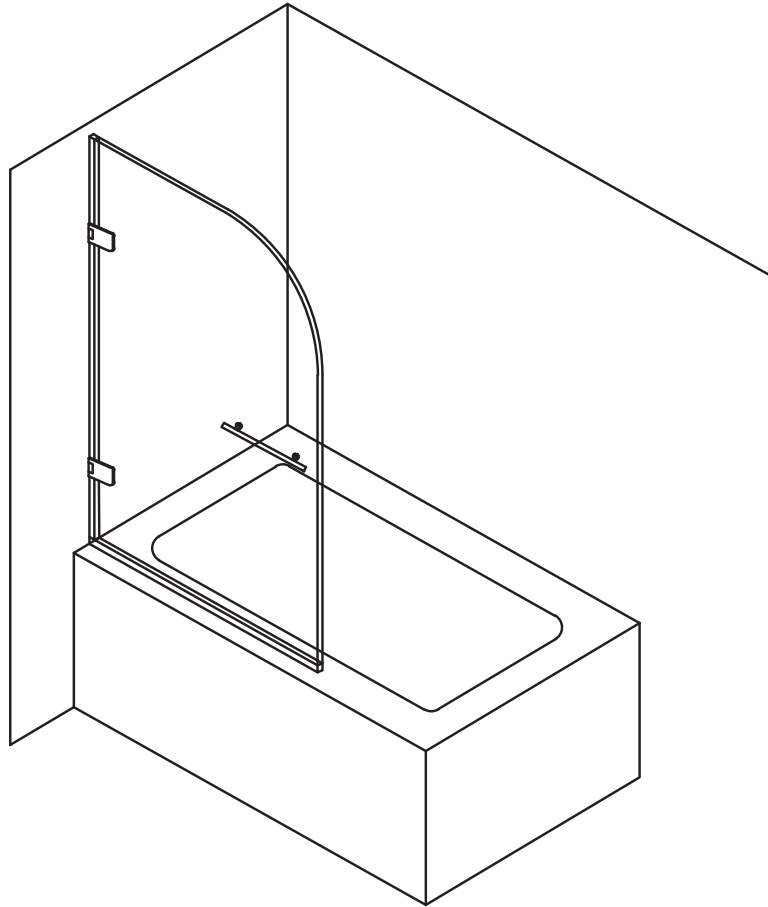

PRODUCT FEATURES





- Designed for install with standard-sized bathtubs
- Includes all mounting hardware
- Constructed from ANSI Z97.1 and 16 CFR 1201-certified tempered glass
- Continuous seal strips along the door prevent leaks, even through door hinges
- High-quality solid brass hardware resists corrosion and tarnishing
- All VIGO Tub Doors feature a quality assured Limited Lifetime Warranty

CODES / STANDARDS



- ANSI 297.1 and 16 CFR 1201-certified glass
- All VIGO Shower Door have a Limited Lifetime Warranty

AVAILABLE FINISHES

Color**	Code	Description
	CH	Chrome
	ST	Stainless Steel
	MB	Matte Black
	MG	Matte Brushed Gold
	ARB	Antique Rubbed Bronze

\* See website for detailed warranty information.

\*\*Color swatches intended for reference only.

MEASUREMENTS

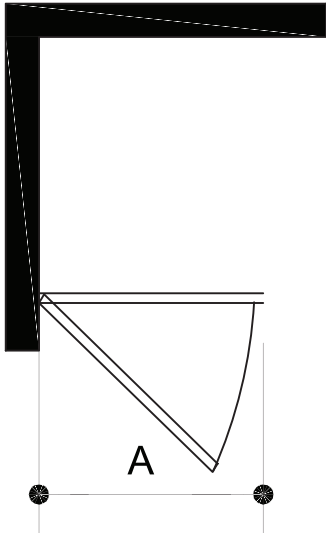

Model	A Door	Height	Door Dimensions
VG6071-3458	34"	58"	34" x 57 3/8"

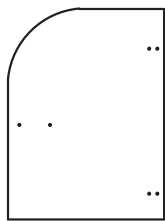
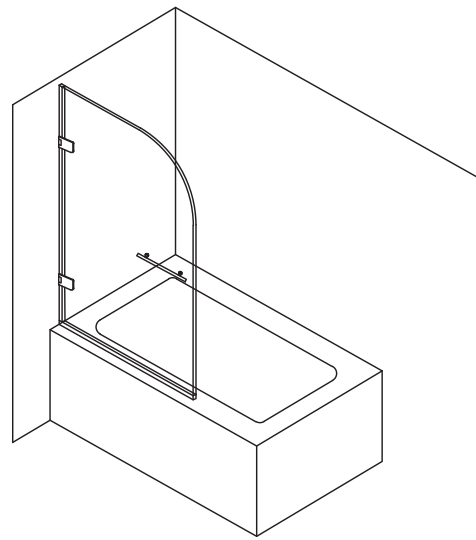
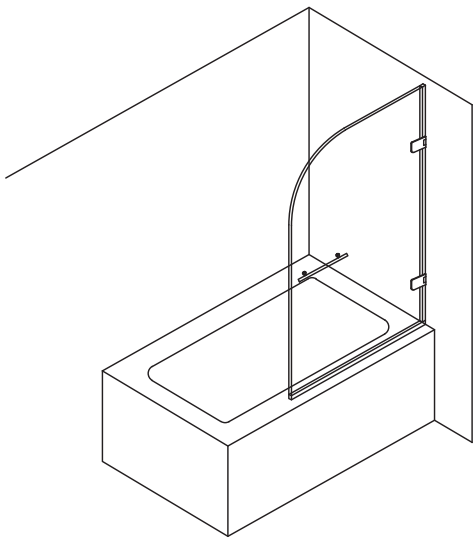

DOOR PANEL

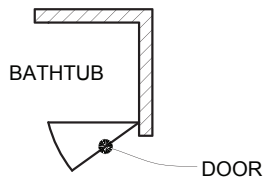

RIGHT CORNER  
INSTALLATION

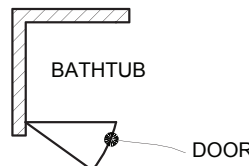

LEFT CORNER  
INSTALLATION

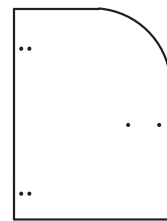

DOOR PANEL